

**INSTRUCTION MANUAL**  
**EAS TELEPHONE INTERFACE**  
**MODEL 985A**  
**S/N \_\_\_\_\_**

IF FOR SOME REASON YOU HAVE TO  
RETURN THIS ITEM TO THE FACTORY  
FOR ANY SERVICE OR REPAIR, YOU  
MUST CONTACT CUSTOMER SERVICE  
FOR AN **RMA** NUMBER AT (716) 765-2254



100 Housel Ave. Lyndonville, N.Y. 14098  
Phone: (716)-765-2254 FAX: (716)-765-9330

## **TABLE OF CONTENTS**

<b>WARRANTY</b>	<b>3</b>
<b>GENERAL DESCRIPTION</b>	<b>4</b>
<b>SPECIFICATIONS</b>	<b>5</b>
<b>INSTALLATION</b>	<b>6</b>
<b>ADJUSTMENTS</b>	<b>7</b>
<b>ATTACHED MANUALS, 3185E AND 3567</b>	

## WARRANTY

Monroe Electronics, Inc. warrants to the owners, each instrument and sub-assembly manufactured by them to be free from defects in material and workmanship for a period of one year after shipment from factory. This warranty is applicable to the original purchaser only.

Liability under this warranty is limited to service, adjustment or replacement of defective parts (other than fuses or batteries) on any instrument or sub-assembly returned to the factory for this purpose, transportation charges prepaid.

This warranty does not apply to instruments or sub-assemblies subjected to abuse, abnormal operating conditions, or unauthorized repair or modification.

Since Monroe Electronics, Inc. has no control over conditions of use, no warranty is made, or implied as to the suitability of our product for the customer's intended use.

THE WARRANTY SET FORTH IN THIS ARTICLE IS EXCLUSIVE AND IN LIEU OF ALL OTHER WARRANTIES AND REPRESENTATIONS, EXPRESS, IMPLIED OR STATUTORY INCLUDING, BUT NOT LIMITED TO THE IMPLIED WARRANTIES OF MERCHANT ABILITY AND FITNESS. Except for obligations expressly undertaken by Monroe Electronics, in this warranty, Owner hereby waives and releases all rights, claims and remedies with respect to any and all warranties, express, implied or statutory (including without limitation, the implied warranties of merchant ability and fitness), and including but without being limited to any obligation of Monroe Electronics with respect to incidental or consequential damages, or damages for loss of use. No agreement or understanding varying or extending the warranty will be binding upon Monroe Electronics unless in writing signed by a duly authorized representative of Monroe Electronics.

In the event of a breach of the foregoing warranty, the liability of Monroe Electronics shall be limited to repairing or replacing the non-conforming goods and/or defective work, and in accordance with the foregoing, Monroe Electronics shall not be liable for any other damages, either direct or consequential.

## RETURN POLICY TO FACTORY:

Materials returned to Monroe must have a Return Material Authorization number. To obtain a RMA number, contact our A/V Switching & Control Customer Service at 716-765-2254 or fax 716-765-9330. Customers have 30 days to determine that the product ordered fills their need and performs as described in Monroe's literature. Units returned for approved repair or credit, must be in the original packaging including all parts and paperwork plus be in very good physical condition. If not, the customer is billed the cost to refurbish the unit and for missing accessories and merchandise. No products may be returned for exchange or credit after 12 months of the shipment date. Monroe reserves the right to repair or replace units under warranty.

# GENERAL DESCRIPTION

This device interfaces a two wire (POTS) telephone service with control switching and modulator input for an EAS system.

It allows the user to determine how many rings will occur before the telephone line is seized.

It allows the user to determine if he wishes to have the unit hang up after a pre-determined time, or if he wishes it to look for the line current interruption (WINK) on the telephone line to effect a disconnect.

A custom message, of up to 20 seconds, may be input by the operator. The message, when entered, should be followed by a short silent period so that the unit can more easily detect the DTMF control tones. When the telephone line detects a ring signal, and after the number of rings selected by the user occur, the line is seized.

The unit then begins playing back the message stored by the operator, and looks for a series of DTMF tones corresponding to the three digit access code.

Upon the telephone caller entering the three number access code - selected via jumpers by the operator - the unit will cease playing the message and proceed to the next stage of operation.

The device will then connect the telephone audio to the input to the modulator, allowing the telephone caller to speak over the EAS system.

Also after the access code has been entered, relays will actuate. The relay is SPST, and all the contacts are available on the screw terminals of the connector.

The unit will continue to allow the operator to speak over the EAS system until one of two things happen:

- The unit times out if the time out option has been set.

- The caller hangs up.

Power is supplied from a 12 VDC plug mounted supply.

# SPECIFICATIONS

**Rings to answer**

Set on 3137B, see manual

**Time out in seconds**

Set on 3137B, see manual

**Access codes**

8 unique

**Power required**

+ 12 VDC , from supplied 110 VAC wall unit

**External switching**

One relay, 2 Amp 30 volts DC non-inductive loads

**Indicator lights**

One both PC cards, see manual

**Audio Adjustments**

Gain for DTMF decoder input, on 3567 card, see manual

**Message length**

Up to 20 seconds

# INSTALLATION

The EBS Coupler is pre-wired and pre-test at the factory. All connections to the EBS coupler are made on the screw terminal barrier strip.

## **Telephone Connection:**

Connect the telephone line **RING** (Red Wire) to TB 1 screw terminal #1 and **TIP** (Green Wire) to TB 1 screw terminal #2.

## **Audio Connections - Switched:**

The telephone audio (balanced) controlled by the internal DTMF Decoder is located on TB 1 screw terminals #5 and #6. Audio is present at these terminals after the calling party enters in the correct access code.

## **Auxiliary Relay Output:**

The auxiliary relay output is located on TB 1 screw terminals #7 and #8. These two screw terminals are electrically open until the calling party enters the correct DTMF access code. Upon entering the correct access code screw terminals #7 and #8 short together and remain shorted until the calling party disconnects. PIN 7 IS GROUNDED INTERNALLY.

## **Power Supply Connections:**

The EBS Telephone Coupler is provided with a Monroe 427 Power Supply module. This module produces +12 VDC regulated at 300 mA. Connect the **White/Black** wire, of the 427, to TB 1 screw terminal #4. Connect the **Black** wire, of the 427, to TB1 screw terminal #3(GND).

# ADJUSTMENTS

All necessary adjustments have been preset at the factory. If further adjustments are needed consult the individual card manuals in the back of this manual for the 3137B and 3567 cards.

The following settings have been made at the factory before shipment:

## 3137B UAD:

- J1 - Set on 2 to answer the second incoming ring signal.
- J2 - Removed to disable disconnect timer.
- J3 - Installed to auto answer ring signal
- J4 - Set across 1 and 2 to disconnect only when calling party disconnects.
- R14 - Set fully counter clockwise for minimum time on timer.

## 3567 Audio Control Board

To record your message:

Depress and hold down the REC button, while speaking at normal voice level about 50 cm from the microphone. When through, release the button. Remember that message duration is limited to 60 seconds.

The default activation code is '911'. This is selected by removing all jumpers from J1 pins 1, 2, and 3. If a different code is desired, install jumpers as shown in the table below to select the indicated codes.

o indicates open, x indicates shorted connection between adjacent pins on J 1.

Adjacent Pins			Code Selected
o	o	o	911
o	o	x	132
o	x	o	321
o	x	x	231
x	o	o	123
x	o	x	628
x	x	o	294
x	x	x	573

**INSTRUCTION MANUAL**  
**UNATTENDED ANSWERING DEVICE**  
**Model 3137B**  
S/N \_\_\_\_\_

**If for some reason, you have to  
return this item to the factory  
for any service or repair, you  
must contact customer service  
for an RMA number, 716-765-2254**



## Table of Contents

DESCRIPTION	3
SPECIFICATIONS	4
INSTALLATION/PIN FUNCTIONS	5
FIGURE 1	6
NOTICE TO USERS/FCC REQUIREMENTS	7-8
DESCRIPTION OF CONNECTIONS	9
USER OPTIONS	10-12
OPERATION	12
THEORY OF OPERATION	12-13
APPLICATIONS/OPTIONS	14-15
EDGE CONNECTORS	16
BOARD PARTS PLACEMENT	17
WARRANTY	18
RETURN POLICIES	18

## Description

The Model 3137B Unattended Answering Device is an auto-answer telephone line coupler. It is intended to provide bi-directional telephone audio for access to remote equipment that is not registered with the FCC for direct connection to the telephone line.

Standard features include:

- Bi-directional audio coupling to and from the telephone line.
- Automatic answering with selectable answer delay.
- Selectable disconnect on loop battery break from Central Office or on fixed time period or both.
- Control lines for locally forced connect and disconnect.
- Auxiliary HOOK SWITCH status contact.
- Optional Dial Tone Detector module.

The Model 3137B is intended primarily for use on telephone lines where the subscriber line loop current is interrupted by the Central Office when the calling party hangs up. However, it may also be used when it is acceptable to disconnect upon a fixed time period after (not to exceed 135 seconds). And also when the coupler is to be placed under control of an external device.

## Specifications

Ring Signal Frequency	16 to 60 Hz.
Ring Signal Voltage	60 to 150 VAC maximum @ 16 Hz
Ring Signal Duration	>250 mm. @ 16 Hz. < 75 ma. @ 60 Hz.
Inter-ring Time	5.5sec. maximum
Insertion Loss	0.3dBm @ -0.1ma. to 25ma. loop current
Input Signal Level	Nominal -12dBm @ 600Ω balanced
Input Signal Frequency	300 Hz. to 5 KHz. for 1:1 transfer ~ 600Ω
Timer	Adjustable 2 to 15 sec. per step; preset to 6 sec. per step. Nine steps are selectable for a maximum time of 135 sec.
Holding Relay Output	Supply voltage minus 2 Volts @ 50 mA maximum
Relay Output	SPDT 30 VDC @ 0.5 Amp
Reset Line	Level Sensitive, Minimum 20 mS Pulse to Ground
Set Line	Level Sensitive, Minimum 20 mS Pulse to Ground
Edge Connector	Monroe Model 3000RK (Cinch Jones 50-20A-30)
Power Requirements	12 Volts DC $\pm$ 10% 60 mA Maximum
Physical Dimensions	5.0 In.H X 3.0 In. W X .6 In. D

## Installation

### Mounting:

The Model 3137B is designed to plug into a Monroe 3000RK 20-pin edge connector (Cinch Jones 50-20A-30). All connections are intended to be made at the edge connector and will be referred to in this manual by edge connector numbers or letters. Consult page 16 for edge connector

### Pin Numbers and Functions:

Pin numbers are listed below for the Model 3137B when plugged into a 3000RK connector. Consult FIGURE 1 page 6 for proper registration of pin numbers.

PIN NUMBER	FUNCTION
1	SET INPUT
3	CIRCUIT COMMON (ground)
4	RESET INPUT
5	E AUDIO INPUT/OUTPUT
6	RING DETECT INPUT (normally connected to pin 'H')
7	CIRCUIT COMMON (ground)
8	+12 VDC POWER SUPPLY INPUT
9	EXTERNAL HOLDING RELAY
10	COMMON TERMINAL OF RELAY OUTPUT REFERENCED TO PINS K AND 'L
A	HOLD INPUT
D	CONTROL INPUT
F	TELEPHONE LINE INPUT (ring)
H	TELEPHONE LINE INPUT (tip)
K	NORMALLY CLOSED CONTACT OF RELAY OUTPUT
L	NORMALLY OPEN CONTACT OF RELAY OUTPUT

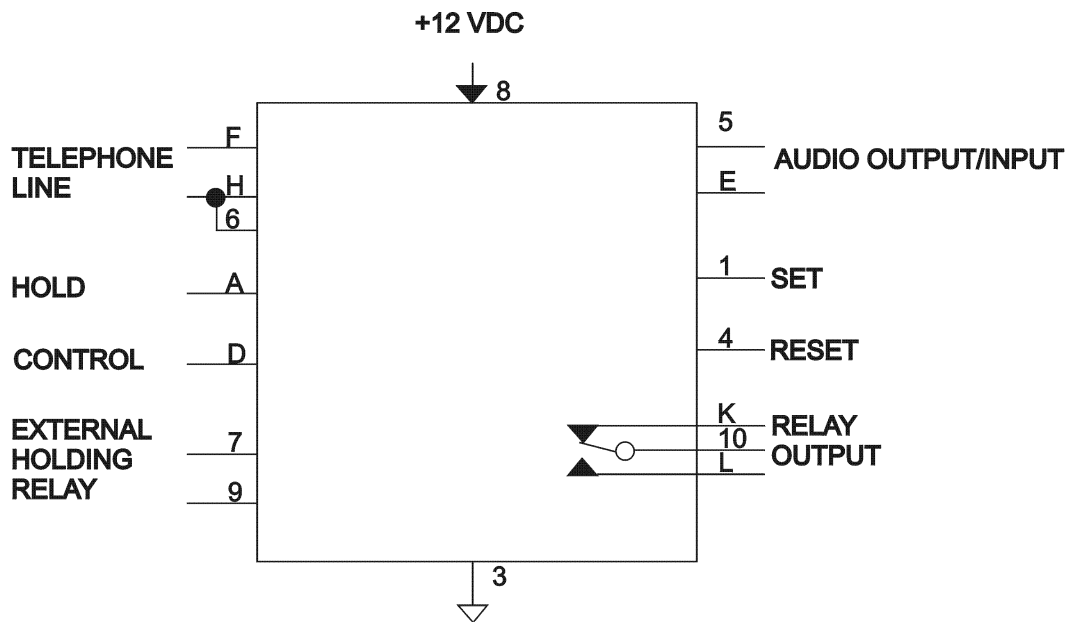
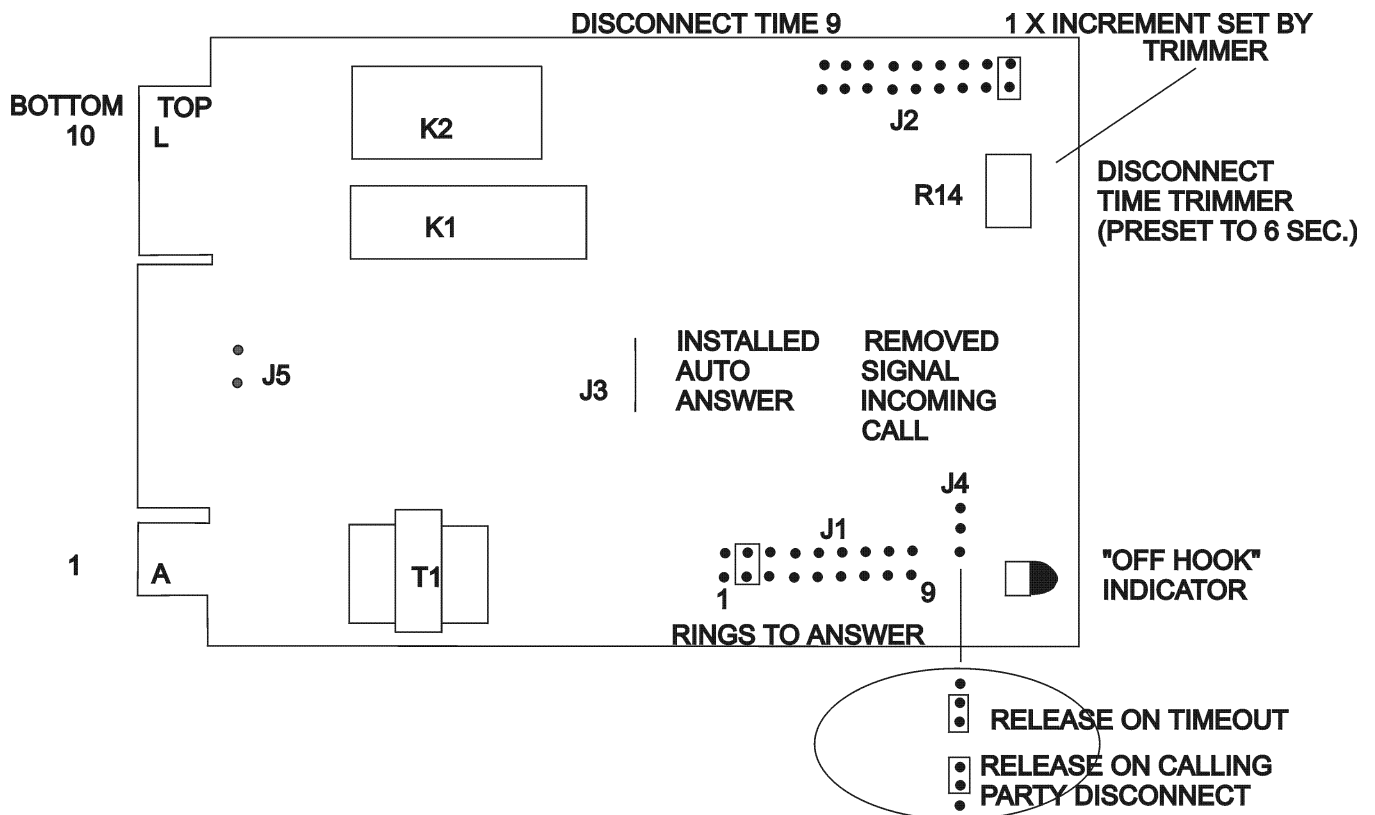

FIGURE 1

## NOTICE TO USERS

Before connecting this device to your telephone line the following information must be supplied to your telephone company

Model Number	3137B
Registration Number	AAK - 99W-67353 -VP-N
Ringer Equivalence	0.3B
Jack Number	RJ IIC

## EXHIBIT J

### USER INSTRUCTIONS

In compliance with FCC part 68, **Customer is Advised**

#### 68.104 Standard Plugs and Jacks

Connection to the network must be through USOC type jack to be supplied by the telephone Company

#### 68.106 Notification to the Telephone Company

Customers connecting terminal equipment to the telephone network shall, before such connection is made, give notice to the telephone company of the particular line(s) to which such connection is to be made and shall provide to the telephone company the FCC registration number and the ringer equivalence of the registered protective circuitry. Notice of final disconnect shall also be given.

#### 68.108 Incident of Harm

Should terminal equipment cause harm to the telephone network, the telephone company shall, where practicable, notify the customer that temporary discontinuance of service may be required; however, where prior notice is not practicable, the telephone company may temporarily disconnect service forthwith, if such action is reasonable in the circumstances. The telephone company shall (1) promptly notify the customer of such temporary discontinuance, (2) afford the customer the opportunity to correct the situation which gave rise to the temporary discontinuance, and (3) inform the customer of his right to bring a complaint to the commission pursuant to the procedure set out in Subpart E of Part 68.

#### 68.100 Changes in Telephone Company Facilities, Equipment, Operations or Procedures

The telephone company may make changes in its communications facilities, equipment, operations or procedures, where such action is reasonably required in the operations of its business and is not inconsistent with the rules and regulations of Part 68.

If such changes can be reasonably expected to render any customer's terminal equipment incompatible with the telephone company communications facilities, or require modification or alteration of such terminal equipment, or otherwise materially affect its use or performance, the customer shall be given adequate notice in writing, to allow the customer an opportunity to maintain uninterrupted service.

68.216 Repair of registered terminal equipment and registered protective circuitry shall be accomplished only by the manufacturer or assembler thereof or by their authorized agent... (this applies at any time during and after the warranty period).

68.218 (b) The grantee or its agent shall provide the user of the registered equipment the following:

- (1) Instructions concerning installation, operation and repair procedures, where applicable.
- (2) Instructions that registered terminal equipment of protective circuitry may not be used with party lines or coin telephone lines.
- (3) Instructions that when trouble is experienced the customer shall disconnect the registered equipment from the telephone line to determine if the registered equipment is malfunctioning, and that if the registered equipment is malfunctioning, the use of such equipment shall be discontinued until the problem has been corrected.
- (4) Instructions that the user must give notice to the telephone company with the requirements of Section 68.106.

The customer will be advised by written instructions of any restrictive conditions under which the apparatus must be used. Such restrictions to include such as only with registered apparatus, or only with specific model numbers.

Grantee agrees to supply each purchaser with a copy of Exhibit J. In addition, grantee assumes responsibility for Quality Assurance in that all equipment manufactured continues to comply with Part 68 standards.

Indicated below is the connecting arrangement (jack) to be ordered from the telephone company. Shown is typical and other Subpart F, Part 68 jacks are available for specific uses.

U SOC  
RJ11C or RJ11W

Telephone Connections:

Connect the telephone line RING (RED WIRE) to Pin F and TIP (GREEN WIRE) to Pin H of the edge connector. Pin 6 (ring detector input) when connected to Pin "H" enables the internal telephone ring detector for auto-answer operation (see FIGURE 1 page 6).

#### Audio Connection:

Telephone audio is available at Pins “5” and “E” (see FIGURE 1 page 6). This is a bi-directional audio port balanced with a source impedance of  $600\Omega$ . The maximum audio level that should be introduced at this point is -9dBm,

#### Auxiliary Relay Contact Connection:

The Form C relay contacts are available at the edge connector. This relay energizes (closes) when the Model 3137B “answers” the incoming call and dc—energizes (opens) when it disconnects,

PIN 10 - COMMON TERMINAL OF SPDT RELAY

PIN K - NORMALLY CLOSED CONTACT OF RELAY

PIN L - NORMALLY OPEN CONTACT OF RELAY

#### Holding Relay Connection:

The holding relay output is intended to drive an external 12 VDC relay whenever the coupler is in the “OFF-HOOK” state, Pin “9” will go to a high logic state (+12 VDC) on answering (referenced to Pin “7”, and will return to a low logic state on disconnect (see FIGURE 1 page 4).

#### Set Input Connection:

Momentarily grounding Pin “1” forces the 3137B to connect to the telephone line without an incoming call or if held at ground after the 3137B has answered an incoming call keeps it from disconnecting by means of CFR or timeout,

#### Hold Input Connection:

Grounding input Pin “A” will not allow the 3137B to seize the telephone line but will keep the on board timer from running thus preventing timeout disconnect until Pin “A” is released from ground. Once released from ground the on board timer starts timing out, and will disconnect the 3137B according to the preprogrammed time.

#### Control Input Connection:

Applying +12 VDC to Pin “D” will cause the 3137B to seize the telephone line and not release it until the +12 VDC is removed. When in this state the reset input Pin “4” will not override the control input Pin “D” controlling the line seize relay.

#### Reset Input Connection:

Momentarily grounding Pin “4” causes the 3137B to disconnect or if held at ground will prevent the 3137B from answering an incoming call, Grounding this input overrides all other 3137B functions except Pin “D”.

#### Supply Input Connection:

The power supply input is connected to Pins “8” (+12VDC) and “3” (circuit common). Consult FIGURE 1 page 6.



## USER OPTIONS

Several plug-In jumpers on the Model 3137B circuit card permit the selection of user options. Refer to FIGURE 1 page 6 for assistance in locating these jumpers.

**TABLE 1  
USER OPTIONS SETUP**

JUMPER	PROGRAM JUMPER NUMBER	OPERATION
J1	1	1 OR 2 RINGS BEFORE ANSWER
J1	2	2 OR 3 RINGS BEFORE ANSWER
J1	3	3 OR 4 RINGS BEFORE ANSWER
J1	4	4 OR 5 RINGS BEFORE ANSWER
J1	5	5 OR 6 RINGS BEFORE ANSWER
J1	6	6 OR 7 RINGS BEFORE ANSWER
J1	7	7 OR 8 RINGS BEFORE ANSWER
J1	8	8 OR 9 RINGS BEFORE ANSWER
J1	9	9 OR 10 RINGS BEFORE ANSWER
J2	1	DISCONNECT IN 6 SECONDS
J2	2	DISCONNECT IN 12 SECONDS
J2	3	DISCONNECT IN 18 SECONDS
J2	4	DISCONNECT IN 24 SECONDS
J2	5	DISCONNECT IN 30 SECONDS
J2	6	DISCONNECT IN 36 SECONDS
J2	7	DISCONNECT IN 42 SECONDS
J2	8	DISCONNECT IN 48 SECONDS
J2	9	DISCONNECT IN 52 SECONDS
J3	INSTALLED	AUTOMATICALLY SEIZES LINE AFTER NUMBER OF RINGS DETERMINED BY J1.
J3		REMOVED SIGNALS INCOMING CALL WHEN AN INCOMING RING SIGNAL IS DETECTED , BUT DOES NOT SEIZE LINE UNTIL EDGE CONNECTOR, PIN '~D'~, IS CONNECTED TO A +12VDC SIGNAL AFTER RING DETECT.
J4	2 AND 3	DISCONNECTS ON TIME-OUT TIME SET BY J2 AND TRIMMER R14.
J4	1 AND 2	DISCONNECT ONLY WHEN CALLING PARTY HANGS UP. THERE MUST BE NO JUMPERS INSTALLED ON J2.

**Answer Time:**

A jumper must be installed at one of the nine positions of ~J1~ to cause the device to automatically answer an incoming telephone call. As such, these nine positions permit the user to select from one to nine ring,~ before answer.

**NOTE:** The device will answer after the number of selected rings. For example, if two rings before answer has been selected then the device will go to the OFF-HOOK state at the end of the second ring.

The simulated ring signal heard by the calling party may not accurately reflect the actual ring timing being delivered to the called station.

#### Disconnect Time:

A jumper must be installed at one of the nine positions of ~'J2~ to cause disconnection after a fixed period of time. This has been set at the factory to provide approximately time increments of six seconds for each of the nine positions. As such, placing the jumper at J2 position 1 causes disconnection after 6 seconds, placing the jumper at J2 position 2 causes disconnection after 12 seconds, etc.

This permits a selection of incremental times up to 54 seconds (nominal). If longer OFF-HOOK times are required, potentiometer RI4 can be adjusted in the clockwise direction. A maximum time of 135 seconds (nominal) is achieved when this potentiometer is in the full clockwise position.

If disconnection on a fixed time basis is not desired then no jumper should be installed in one of the J2 positions.

#### **CAUTIONARY**

**NOTE:** If no jumper is installed in one of the J2 positions then some other means of disconnect should be employed to guarantee disconnect. This may be either external reset from a controlling device or by detection of loop battery interruption.

Disconnection upon detection of loop current interruption (J4) and disconnection by fixed time-out (J2) may both be selected. In this circumstance the device will disconnect according to whichever signal occurs first.

#### Disconnection Upon Detection of Loop Current Interruption

Jumper J4 is used to select disconnection upon detection of a loop current interruption from the Central Office.

This is a two-position jumper and the jumper must be installed in one of the two available positions. Failure to place the jumper in one of the two available positions may result in improper operation of the device.

Jumper J4 must be installed in the position as described in FIGURE 1 for disconnection upon detection of loop current interruption or else it must be installed in the alternate position as described in FIGURE 1 if disconnection upon detection of loop current interruption is NOT desired.

Disconnection upon detection of loop current interruption (J4) and disconnection by fixed time-out (J2) may both be selected. In this circumstance the device will disconnect according to whichever occurs first.

#### Answer/Signal Mode Selection:

Jumper J3 is installed and should remain installed for normal operation of this device. Jumper J3 should be removed only if an external device is to control answer and disconnect.

Jumper J3 can be removed to cause the device not to answer an incoming call. In this circumstance the answering device will close the auxiliary hook switch contact after the number of rings before answer (as selected by jumper Ji) to signal an external device of the incoming call but will not terminate the telephone line (go OFF-HOOK).

An external control device would instruct the Unattended Answering Device to answer the incoming call by taking the control line (3137B card edge Pin ~D') to ~V (nominally +12 VDC).

The external control device would maintain this control line at +V until it wanted to be disconnected from the telephone line. It would then remove the +V from the control input of the Unattended Answering Device. The Unattended Answering Device would disconnect from the telephone line immediately upon release of the control line by the external control device.

Disconnection upon loop current interruption by the Central Office should also be selected on J4 for proper resetting of the Unattended Answering Device in this mode.

## **OPERATION**

The device will answer an incoming call after the number  $0 \pm$  rings prescribed by J1 and complete a bi-directional audio path between the telephone line and the non-network audio port.

It will remain on the line until the calling party disconnects and a loop battery interruption is given to the called party or until it times out as prescribed by jumper programming.

## **THEORY OF OPERATION**

A ring signal is applied to the telephone line by the Central Office.

This signal is passed from the telephone line to the ring detector circuit, A1, on the 3137B. A1 demodulates the envelope of the ring signal and passes each ring through PC1 and A2B to the ring counter, A3.

The counter is advanced each time a ring is detected from the telephone line.

The selected output of this counter (corresponding to the number of rings before answer) is passed through J1 to a latch, A4, which is then SET.

The SET condition at this latch causes Ki to energize by way of A2C, J3 and Q3. This seizes the telephone line.

At the same time the setting of latch A4 operates K1, it also enables the disconnect oscillator, A2D.

A2D generates a clock pulse to the counter A6 which is advanced with each pulse from the oscillator.

The selected output of this counter is a reset pulse that passes through A5C, CR9 and A2E to reset the ring counter, A3 and the latch A4. Resetting the latch A4 causes K1 to be dc-energized (releasing the telephone line) and the disconnect time oscillator, A2D to be disabled and the disconnect time counter is reset via A5D.

If disconnection upon loop current interruption is selected then telephone loop current illuminates PC2 after K1 energizes.

When the current interruption is detected from the Central Office then the transistor of PC2 is turned OFF. This serves as a reset signal which is passed through A5B and CR8 to reset the system as in the circumstance of the reset on disconnect timer time-out.

Dial Tone Disconnect Option:

For telephone exchanges where the Central Office does not provide a current interruption on the calling party disconnect, return of dial tone can be used to force disconnect of the Model 3137B.

Model 90417:

An optional Model 90417 Dial Tone Detector module may be added to the 3137B for detection of continuous dial tone. The 90417 replaces the A2 IC, plugging directly into A2's socket and connecting two wires to J5. After detecting continuous dial tone the 90417 module will reset the 3137B.

Interconnecting Two Telephone Lines:

Two 3137B's can be used to interconnect two telephone lines, permitting the user to call in on one line and DTMF dial out on the second line. The dial tone disconnect option is recommended when using this configuration to provide reliable disconnect upon return of dial tone from either direction.

Where the combined telephone line loss are too great a bi-directional amplifier may be required. The amplifier may be placed on either of the two lines on the telephone line side of the 3137B.

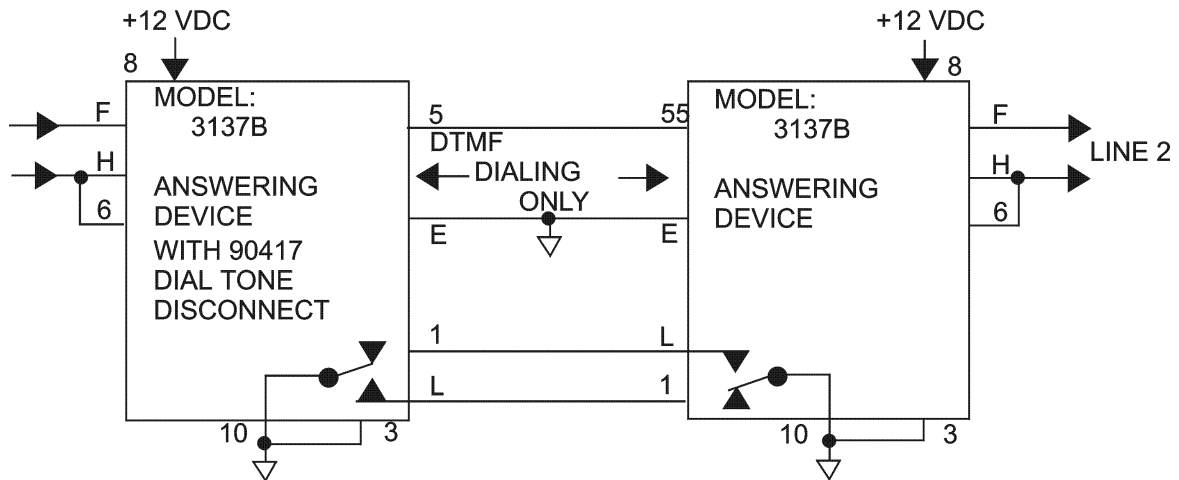

### Interconnecting Four Wires To The Telephone Line:

The 3147-1 Hybrid Coupling Network can be used to interconnect four wire circuits to a standard telephone line. The 3147-1 provides telephone line impedance balance, isolation and signal separation for interconnections to separate four wire transmitter and receiver circuits to a two wire bi-directional audio path. This audio path, when connected to the 3137B, provides an interconnect to a standard telephone line.

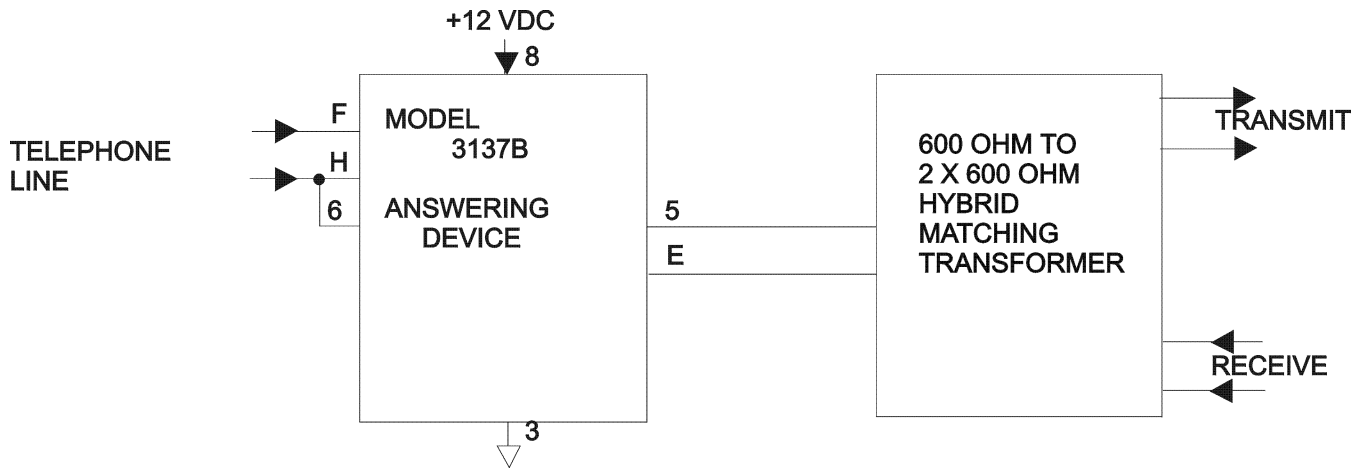

### Telephone Access of Audio:

The Model 3185E Dual Tone Decoder can be used to provide a telephone access code. As shown below a access code must be entered after the 3137B answers the telephone line to complete a bi-directional audio path. If wired as shown, the access decoder will reset when the 3137B disconnects from the telephone line providing maximum security.

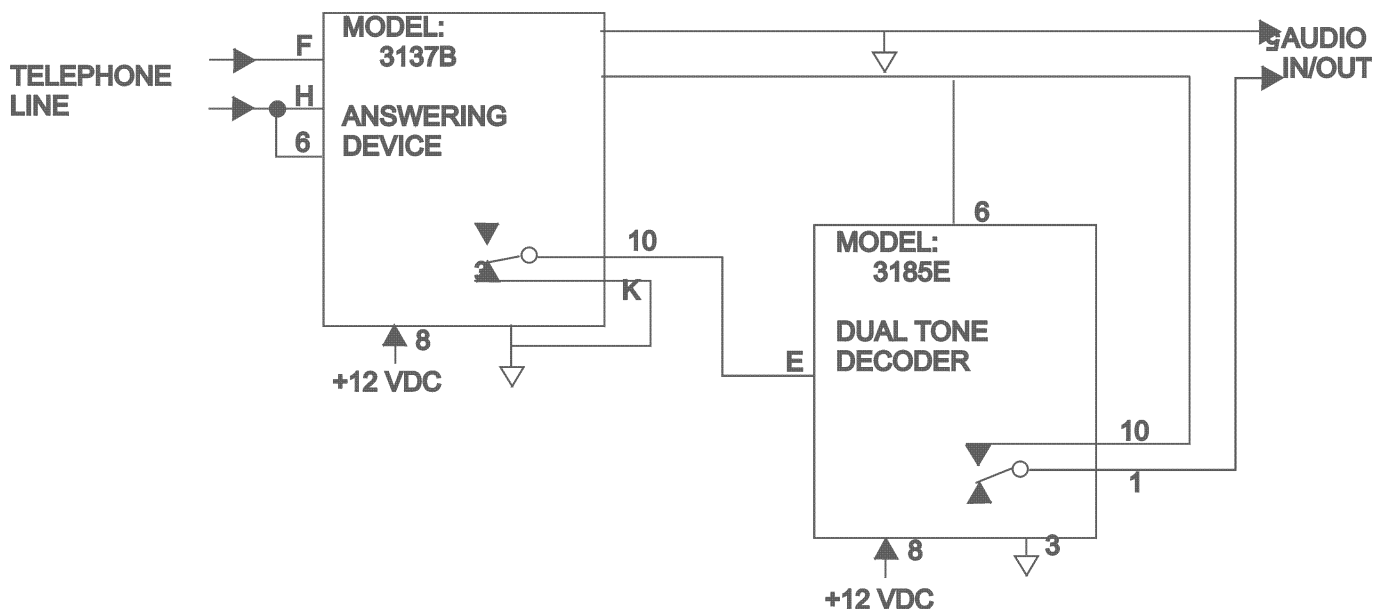

EDGE CONNECTORS

3000RK CONNECTOR

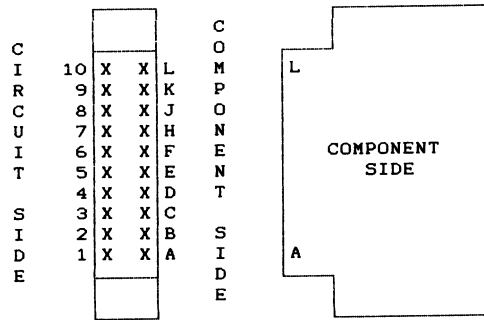

3000SK CONNECTOR

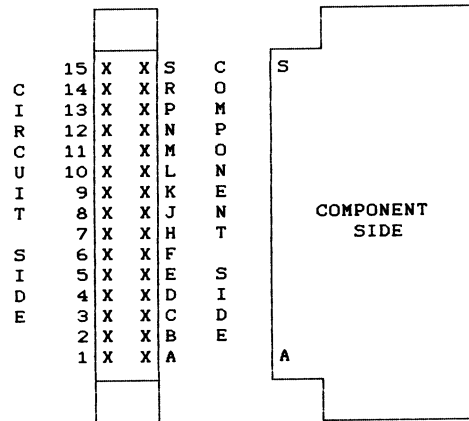

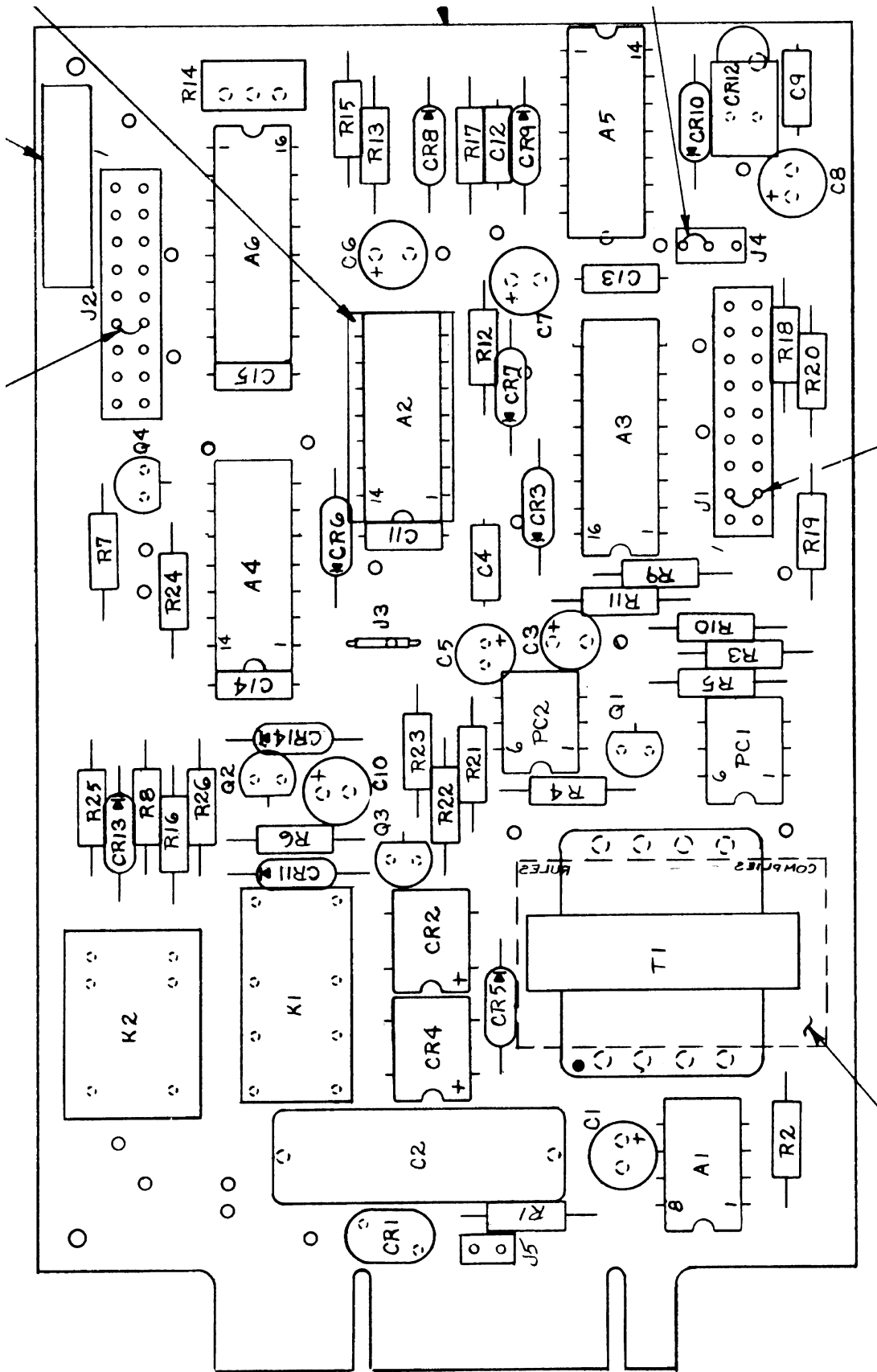



## **WARRANTY**

Monroe Electronics, Inc. warrants to the owners, each instrument and sub-assembly manufactured by them to be free from defects in material and workmanship for a period of one year after shipment from factory. This warranty is applicable to the original purchaser only.

Liability under this warranty is limited to service, adjustment or replacement of defective parts (other than fuses or batteries) on any instrument or sub-assembly returned to the factory for this purpose, transportation charges prepaid.

This warranty does not apply to instruments or sub-assemblies subjected to abuse, abnormal operating conditions, or unauthorized repair or modification.

Since Monroe Electronics, Inc. has no control over conditions of use, no warranty is made, or implied as to the suitability of our product for the customer's intended use.

**THE WARRANTY SET FORTH IN THIS ARTICLE IS EXCLUSIVE AND IN LIEU OF ALL OTHER WARRANTIES AND REPRESENTATIONS, EXPRESS, IMPLIED OR STATUTORY INCLUDING, BUT NOT LIMITED TO THE IMPLIED WARRANTIES OF MERCHANT ABILITY AND FITNESS. Except for obligations expressly undertaken by Monroe Electronics, in this warranty, Owner hereby waives and releases all rights, claims and remedies with respect to any and all warranties, express, implied or statutory (including without limitation, the implied warranties of merchant ability and fitness), and including but without being limited to any obligation of Monroe Electronics with respect to incidental or consequential damages, or damages for loss of use. No agreement or understanding varying or extending the warranty will be binding upon Monroe Electronics unless in writing signed by a duly authorized representative of Monroe Electronics.**

In the event of a breach of the foregoing warranty, the liability of Monroe Electronics shall be limited to repairing or replacing the non-conforming goods and/or defective work, and in accordance with the foregoing, Monroe Electronics shall not be liable for any other damages, either direct or consequential.

## **RETURN POLICY TO FACTORY:**

Materials returned to Monroe must have a Return Material Authorization number. To obtain a RMA number, contact our A/V Switching & Control Customer Service at 716-765-2254 or fax 716-765-9330. Customers have 30 days to determine that the product ordered fills their need and performs as described in Monroe's literature. Units returned for approved repair or credit, must be in the original packaging including all parts and paperwork plus be in very good physical condition. If not, the customer is billed the cost to refurbish the unit and for missing accessories and merchandise. No products may be returned for exchange or credit after 12 months of the shipment date. Monroe reserves the right to repair or replace units under warranty.

**INSTRUCTION MANUAL  
AUDIO CONTROL BOARD  
MODEL 3567**

**S/N** \_\_\_\_\_

IF FOR SOME REASON YOU HAVE TO  
RETURN THIS ITEM TO THE FACTORY  
FOR ANY SERVICE OR REPAIR, YOU  
MUST CONTACT CUSTOMER SERVICE  
FOR AN **RMA** NUMBER AT (716)-765-2254.



100 Housel Ave. Lyndonville, N.Y. 14098  
Phone: (716)-765-2254 FAX: (716)-765-9330

# TABLE OF CONTENTS

<b>WARRANTY PAGE</b>	<b>3</b>
<b>GENERAL DESCRIPTION</b>	<b>4</b>
<b>SPECIFICATION</b>	<b>5</b>
<b>INSTALLATION</b>	<b>6</b>
<b>OPERATION</b>	<b>6</b>
<b>SETUP</b>	<b>6</b>
<b>DIAGRAMS</b>	<b>7</b>

## WARRANTY

Monroe Electronics, Inc. warrants to the owners, each instrument and sub-assembly manufactured by them to be free from defects in material and workmanship for a period of one year after shipment from factory. This warranty is applicable to the original purchaser only.

Liability under this warranty is limited to service, adjustment or replacement of defective parts (other than fuses or batteries) on any instrument or sub-assembly returned to the factory for this purpose, transportation charges prepaid.

This warranty does not apply to instruments or sub-assemblies subjected to abuse, abnormal operating conditions, or unauthorized repair or modification.

Since Monroe Electronics, Inc. has no control over conditions of use, no warranty is made, or implied as to the suitability of our product for the customer's intended use.

THE WARRANTY SET FORTH IN THIS ARTICLE IS EXCLUSIVE AND IN LIEU OF ALL OTHER WARRANTIES AND REPRESENTATIONS, EXPRESS, IMPLIED OR STATUTORY INCLUDING, BUT NOT LIMITED TO THE IMPLIED WARRANTIES OF MERCHANT ABILITY AND FITNESS. Except for obligations expressly undertaken by Monroe Electronics, in this warranty, Owner hereby waives and releases all rights, claims and remedies with respect to any and all warranties, express, implied or statutory (including without limitation, the implied warranties of merchant ability and fitness), and including but without being limited to any obligation of Monroe Electronics with respect to incidental or consequential damages, or damages for loss of use. No agreement or understanding varying or extending the warranty will be binding upon Monroe Electronics unless in writing signed by a duly authorized representative of Monroe Electronics.

In the event of a breach of the foregoing warranty, the liability of Monroe Electronics shall be limited to repairing or replacing the non-conforming goods and/or defective work, and in accordance with the foregoing, Monroe Electronics shall not be liable for any other damages, either direct or consequential.

## RETURN POLICY TO FACTORY:

Materials returned to Monroe must have a Return Material Authorization number. To obtain a RMA number, contact our A/V Switching & Control Customer Service at 716-765-2254 or fax 716-765-9330. Customers have 30 days to determine that the product ordered fills their need and performs as described in Monroe's literature. Units returned for approved repair or credit, must be in the original packaging including all parts and paperwork plus be in very good physical condition. If not, the customer is billed the cost to refurbish the unit and for missing accessories and merchandise. No products may be returned for exchange or credit after 12 months of the shipment date. Monroe reserves the right to repair or replace units under warranty.

## GENERAL DESCRIPTION

The Model 3567 Audio Control Board is a 3"x5" circuit card module designed to record and replay a message, and then detect the proper DTMF tone sequence to pass telephone line audio to an external modulator. It also will control, through it's included normal open relay contacts, the users devices.

## **SPECIFICATIONS**

Power Requirements  
+12VDC @ 75 mA

Physical  
5"H x 3"W x 0.6"D

## INSTALLATION/DIAGRAMS/SETUP

The 3567 is designed to plug into a Monroe model 985A EBS Telephone Coupler.

The DTMF audio input level from the 600 ohm transformer on the 3137B is adjustable. Normal position is in the center of it's range. Generally, problems arise if the level into the DTMFÒ decoder are too high.

The code sequence is defaulted to '911' if all three pin pairs on jumper J1 are open.

Refer to the chart in the 985A manual for settings for other sequences. These would only be used if the other sequence has been compromised.

To record a message on the unit, remove the top cover, and supply power to the 985A. While pushing SW1, the small black push-button switch, and with your mouth from 6 to 10 inches from the small microphone, speak in a normal level, clear voice as you wish the message to be replayed. When you are finished, release the switch.

When calling the unit, the message will automatically play back continuously, until the proper DTMFÒ sequence has been received.

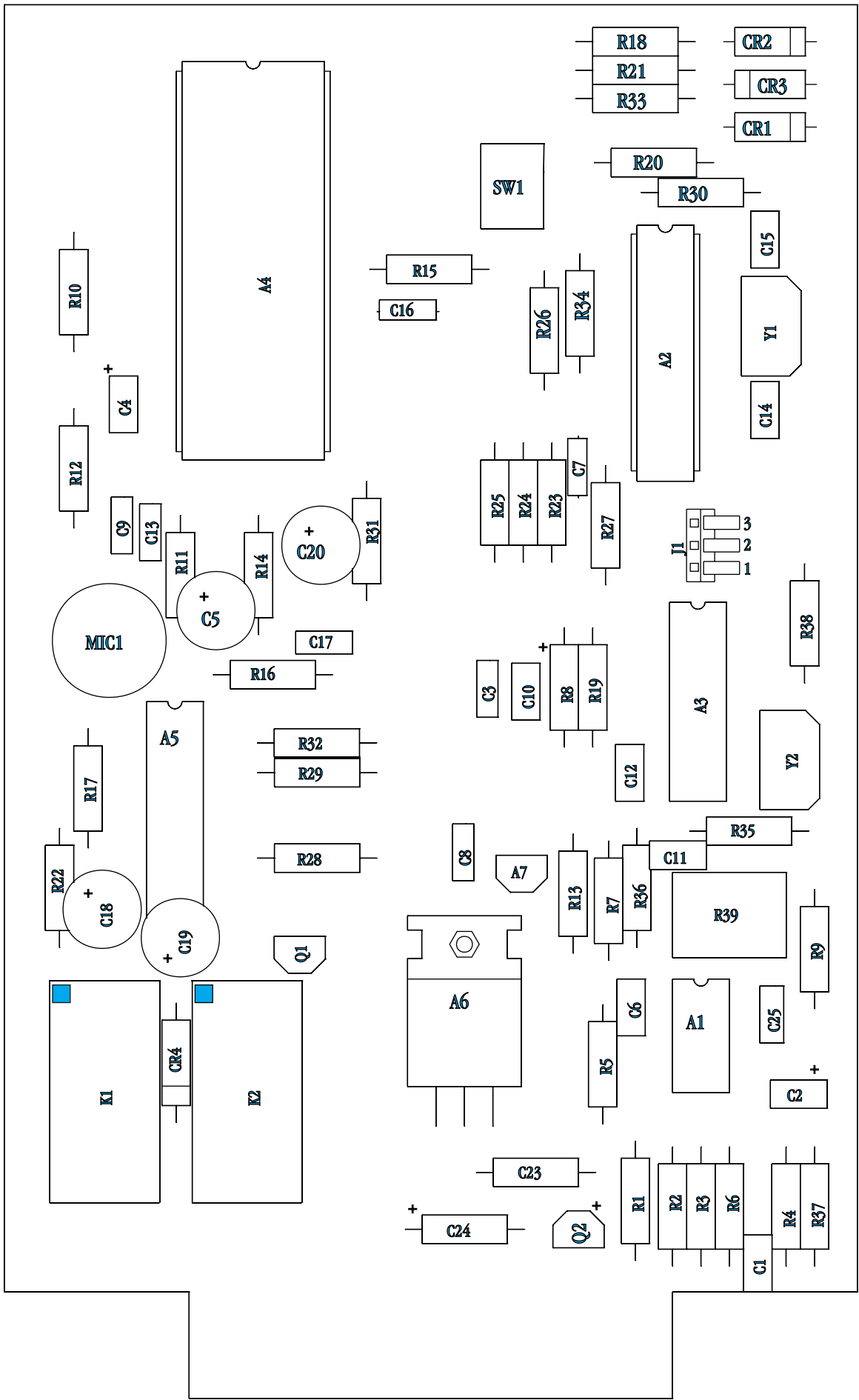

**J1**  
**JUMPER CODE**  
 O=OPEN  
 X=SHORTED  
**J1 J2 J3 CODE**  
 O O O 911  
 O O X 132  
 O X O 321  
 O X X 231  
 X O O 123  
 X O X 628  
 X X O 294  
 X X X 573